



VECTOR ROTARY LATCH - INLINE BOTTOM PULL

Vector rotary latches offer concealed latch points with convenient push-to-close action. Vector Rotaries are suitable for a variety of applications that require high strength, robust and secure latching. They are employed either as single latch point or in a multipoint latching system. Available in either single or two stage latching. The two stage rotary offers a safety feature that securely latches a partially latched compartment. Specially engineered to offer minimized trigger release force that ensures smooth and easy opening.

Vector rotaries are combined with Vector actuators that connect to the rotary latch by Vector rods or cables, creating an optimized latching system with components easily and securely fitted together. Please see related products to choose your components for your complete Vector rotary latching system.



MATERIAL

Anti Vibration Bushing: TPE
Lagerbuchse: Polyamid glasfaserverstärkt (PA6GF30)
Cam: Edelstahl 316
Sicherungsclip: Stahl, verzinkt
Gehäuse: Stahl, verzinkt
Schließhaken: Zinc die cast, zinc plated or black powder coated
Hebel: Gehärteter Stahl, verzinkt

ÄHNLICHE PRODUKTE

Needed components for a complete system:

2-850, 2-745, 2-746, 2-835, 2-860

Ähnliche Produkte: 2-750-01, 2-750-03, 2-750-04, 2-750-07

Use the Index Code at industrilas.com

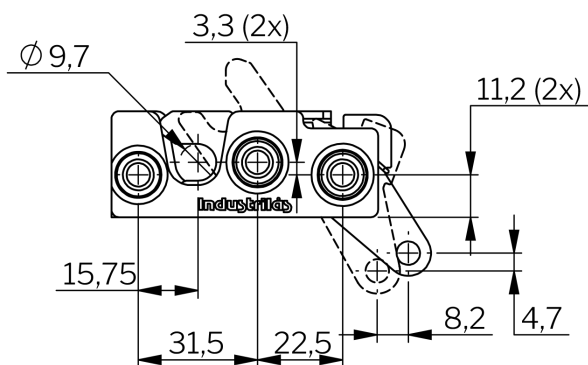
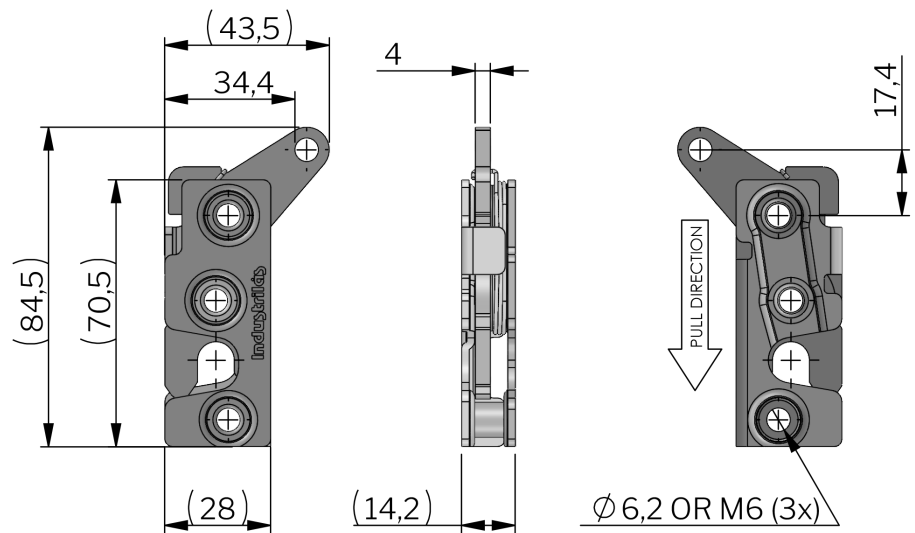

Industrilas
 — When access counts —

A product number is created by combining the figures in each column (AAAA-BBCDEFFG-HH)

AAAA	Type	BB	Material	C	Type	D	Type of jaw	E	Mounting hole	FF	Hebel	G	Links / Rechts	HH	Schließhaken
5223	Rotary for 9,4 mm striker	11	Stahl, verzinkt	1	Single stage	1	Single jaw	0	Through hole	02	Inline Bottom Pull	1	Recht	00	No striker
5224	Anti-BSR* Rotary for 9,4 mm striker			2	Double stage			1	M6 threaded			2	Links	01	With striker bolt UNC 5/16-18
								2	UNC 1/4-20					02	With striker bolt M8
														03	With looped striker
														04	With riveted striker

* Anti-BSR means no Buzz, Squeak or Rattle due to TPE anti vibration bushing.

